

How to optimize the wetting of a tire test track

PNR Italia designs a system of nozzles and manifolds for the wetting of a tire test track



SCENARIO FOR THE SECTOR

All tires on the market pass a fundamental phase which is that of the **track test**. The tires are tested on all types of surfaces, providing extremely precise and detailed measurements with subjective and objective evaluations to the designers.

Experimental evidence is used by researchers to **validate simulation mathematical models**. The practical tests must take place under specific and repeatable conditions, in controlled places, known in the most technical aspects.

The asphalt conditions, constantly monitored, offer both tire and vehicle manufacturers an infinite number of possible maneuvers and tests in complete safety and controllable conditions.

Most of the test tracks are equipped with a bottom wetting system and **one of the fundamental tests that are carried out is that of the grip of the tire on wet asphalt**.

THE PROBLEM OF OUR CLIENT

For the design of a wetting system of a track for wet tests, PNR Italia collaborated with a professional in the field (www.lucabertolio.it) and with the technical team of a circuit for cars and motorcycles that also deals with research, development, certifications, and approvals for cars, motor vehicles, and industrial vehicles.

There were two systems to be designed:

1 | WETTING SYSTEM

A wetting system for the wetting of the track with modular and controllable quantities of water;

2 | WATER WALL

A system perpendicular to the track that reproduces a sudden encumbrance through a wall of water.

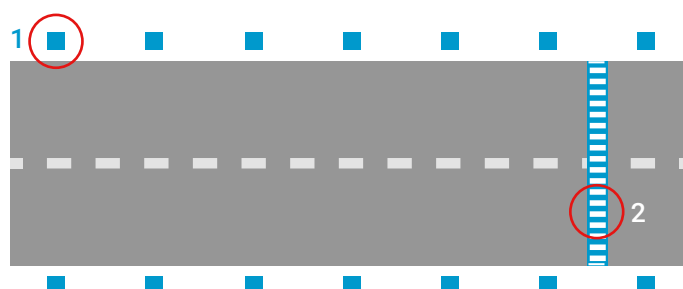

INDUSTRY

Automotive industry
Tire production



APPLICATION OF PNR PRODUCTS

Wetting of a tire test track



PROBLEM

Need for high performances
of controlled wetting



PNR SOLUTION

System of manifolds
and cluster heads spray nozzles



PNR SOLUTION

The Technical Office of PNR Italia, in collaboration with an industry professional (www.lucabertolio.it), developed the two solutions, the first for wetting and the second for the water wall.

WETTING SYSTEM

A wetting system is conceived in which multiple cluster heads are equipped each with seven BS series nozzles. The nozzle cluster heads are secured to shafts with special slots to allow the liquid to pass. A sump protects the wetting system, minimizing the risk of contact objects with vehicles that could pass over them or with foreign objects that could be channeled into the cracks.

WATER WALL

The system for the water wall designed by PNR Italia involves the use of three in-line manifolds perpendicular to the track within a channel below street level, each manifold equipped with 10 J nozzles.

The coverage is complete and uniform over the entire treated surface, allowing the wall of water to reach 3 meters in height. A grille with slits at the nozzles protects the collectors from passing cars.

ADVANTAGES FOR OUR CLIENT

The wetting system developed by PNR Italia guarantees the customer a controlled and efficient wetting. The resulting savings are of an economic and environmental nature.

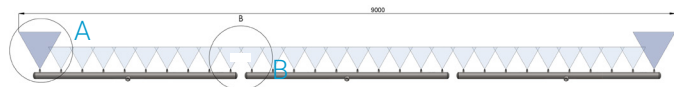

WATER WALL SYSTEM
THREE IN-LINE MANIFOLDS AND NOZZLES

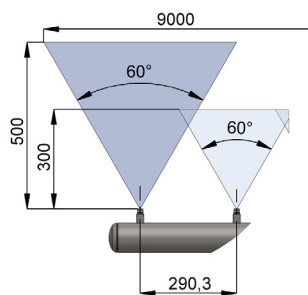

DETAIL A

The water wall will reach a length of 9 meters at a height of 500mm

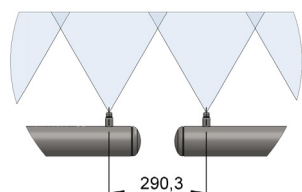

DETAIL B

The center distance identified between the nozzles guarantees a uniform water wall at a height of 300mm

FOCUS ON THE PRODUCT



BS FULL CONE NOZZLE
NARROW SPRAY ANGLE

BS full cone nozzle produces a solid cone spray with a round spray pattern, where coarse water drops are concentrated within a narrow spray angle to maximize their impact force per square surface unit.



J FLAT FAN NOZZLE

Standard flat fan nozzles are available in a wide range of different capacities, spray angles, thread sizes, and materials. Used in several industrial applications, they produce a mist spray and supply an appropriate force of impact.

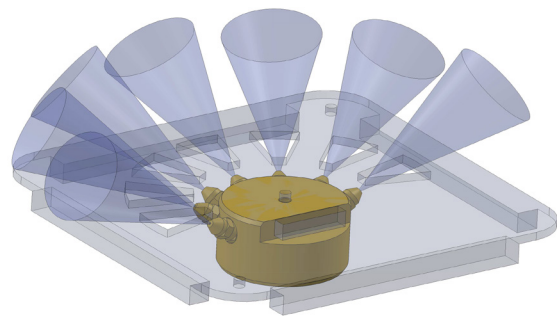

WETTING SYSTEM
THREE-DIMENSIONAL REPRESENTATION

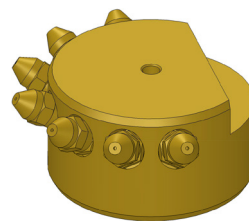

WETTING SYSTEM
THREE-DIMENSIONAL REPRESENTATION
CLUSTER HEAD AND SHAFT

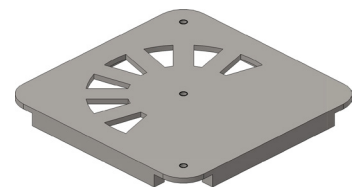

Contacts of the professional who deals with the design of special hydraulic systems dedicated to both Test Tracks of vehicles and ADAS Centers (Advanced Driver Assistance Systems):



LUCA BERTOLIO

Vicolo G. Garibaldi, 4 - 28010 Nebbiuno (NO), Italy
Phone +39 348 4437499

LUCA BERTOLIO E-mail: studio@lucabertolio.it - Web: www.lucabertolio.it

PNR ITALIA SRL

Via Gandini 2, 27058 Voghera (PV), Italy
For more information visit www.pnr.eu

Call or write us for customized solutions!

+39 0383 344 611 info@pnr.it